

**EMBASSY OF INDIA**

545-547, Merchant Street

Post Box No. 751

Yangon, Myanmar

Tel: (951) 391219, 243972, 388412

Fax: (951)254086, 250164, 388414

Website: [www.embassyofindiayangon.gov.in](http://www.embassyofindiayangon.gov.in)Email: [adm.yangon@mea.gov.in](mailto:adm.yangon@mea.gov.in)

NO.YAN/ADM/872/2/2021

Date: 07.04.2021

**NOTICE INVITING TENDER**

Sealed tender is invited from reputed and registered contractors/firms for up gradation of Guard house at Embassy Residence at No. 35, Thantaman Road, Dagon Township, Yangon. The critical dates are as follows:

SI No.	Items of work	Date
1	Publishing Tender Documents	07.04.2021
2	Site visit	08.04.2021 to 12.04.2021 & 20.4. 2021 to 23.4.2021
3.	Last date for Submission of Tender Documents	10.05.2021 at 1100 hrs.
4	Opening of Technical bid	10.05.2021 at 1200 hrs.
5.	Opening of Financial bid	10.05.2021 at 1600 hrs.

Scope of Work is as follow and per drawings with dimensions attached:

SI. No	Item of works
1.	Earthwork Excavation for foundation
2.	Brick work
3.	1:3:6 cement concrete (including floor topping)
4.	Plastering work
5.	1:2:4 concrete work

6.	Painting work, Internal & External (Nippon paint-3 years warranty)
7.	Window(1.2mm thk; power coated frame, 5mm thk; clear glass- Singapore made mosquito net included; grill)
8.	Iron grill-1/2" Solid Iron
9.	Teak door (1.5" thk; Door with lock & paint included)
10.	Formwork for slab
11.	Rebar- 10mm-slab(2 Layer-Both direction)
12.	4"x2" I-Beam – 10'-0" (For overhead water tank)
13.	Tiling work(Bath & WC room)
14.	Electrical & Sanitary ware

2. The tenderers are advised to visit the site to assess the required work and familiarize themselves with the conditions. The tenderers may, accordingly, quote their rates for the above work. The tenderers may call to Embassy (Tel: 391219 / 388412 / 243972) for any clarification regarding the above tender.
3. The rates quoted shall include cost of all materials, labour, tools and any other expenses related with upgradation of guard house.
4. The successful tenderer will have to commence the work within 7 days of issuing Work Order. After completion of the work, the successful tenderer will be required to ensure that the area is not spoilt and the area is cleaned properly.
5. Warranty of the work should be of 2 years from completion of work.
6. The tenderers shall submit the Earnest Money Deposit (EMD) of **Kyats 500000/- (Kyats Five lakh Only)** in cash/Bank draft along with Tender documents. The EMD in respect of all unsuccessful tenderers will be returned after work order is issued to the successful tenderer. The EMD in Bank draft should remain valid for at least 120 days.
7. The successful bidder shall be obliged to deposit an amount equivalent to 5% of the value of the contract to be awarded as performance Bank guarantee in the form of BG/cash. 50% performance guarantee will be refunded after 1 year of completion of work and 50% after 2<sup>nd</sup> of year of completion of work. The bid security shall be refunded to the successful bidder on the receipt of the performance guarantee.
8. The payments will be released to contractors after satisfactory completion of the work. The payment will be released through direct bank transfer/cash in the name of the firm.

9. The submission of a tender by a tenderer implies that he had read this notice and the conditions of contract and has made himself /herself aware of the scope and specifications of work to be done and local conditions of work.
10. The Embassy does not bind itself to accepting the lowest tender nor give any reasons thereof. Embassy reserves the right to cancel the tender at any stage.
11. Tenderers should quote the rate in **Kyats** in neat, legible form and in figure as well as words. Alteration, erasures and indistinct figures should be avoided. Any corrections in the quoted rates shall be made in ink only and shall be signed by the tenderer.
12. The bid should remain valid for at least 90 days & the work should be completed within 30 days after issue of work order.
13. Eligibility Criteria: The Contractor/ Firms submitting bids should have experience of at least four years in the above business and should be registered with the relevant Myanmar government offices as is required under the local regulations for tax and other purposes.
14. Interested vendors should submit Technical Bid and Financial Bid separately in two separate sealed envelopes clearly super scribed "**FINANCIAL BID for up gradation of Guard house at Embassy Residence 2021**" and "**TECHNICAL BID for up gradation of Guard house at Embassy Residence at Embassy Residence 2021**" along with all relevant documents within the specified date and time. A bid sent through Fax or e-mail will not be accepted. The Technical Bid and Financial Bid **SHOULD NOT BE** in the same envelope.
15. Tender for the above work may be submitted to "**Head of Chancery, Embassy of India, 545-547, Merchant Street, Yangon. Last date for receipt of tender is 10<sup>th</sup> May, 2021 till 11:00 hrs. Tenders will be opened on the same day at 12:00 hrs.** in presence of bidders, who have submitted tenders and may wish to be present.



(Sankar Nandi)  
Head of Chancery  
Embassy of India

**TECHNICAL BID FOR “UPGRATION OF GUARD HOUSE AT EMBASSY RESIDENCE 2021” AT NO. 35 THANTAMAN ROAD, DAGON TOWNSHIP, YANGON.**

**Tender Ref. NO.YAN/ADM/872/2/2021 dated 07.04.2021**

- 1.Name of the Company:
- 2.Name of the contact person:
- 3.Contact details:

Phone	
E-mail01	
Postal Address:	

4.The company agrees to all terms of the **“UPGRATION OF GUARD HOUSE AT EMBASSY RESIDENCE 2021” AT NO. 35 THANTAMAN ROAD, DAGON TOWNSHIP, YANGON.**

- 5.Provide contact details and key personnel of the company.
- 6.Furnish proof of registration of the Company in compliance/under relevant statutory regulations of Myanmar law.
7. Furnish proof of four similar works carried out in the past.

Signature

Name

Designation:

Seal:

**FINANCIAL BID FOR "UPGRATION OF GUARD HOUSE AT EMBASSY RESIDENCE 2021"**  
**AT NO. 35 THANTAMAN ROAD, DAGON TOWNSHIP, YANGON.**

**Tender Ref. NO. YAN/ADM/872/2/2021 dated 07.04.2021**

Name, address, Mobile No. of the contractor/firm:	
---	--

Sl. No	Item of works	Total Amount in Kyats
1.	Earthwork Excavation for foundation	
2.	Brick work	
3.	1:3:6 cement concrete (including floor topping)	
4.	Plastering work	
5.	1:2:4 concrete work	
6.	Painting work, Internal & External (Nippon paint-3 years warranty)	
7.	Window(1.2mm thk; power coated frame, 5mm thk; clear glass-Singapore made mosquito net included; grill)	
8.	Iron grill-1/2" Solid Iron	
9.	Teak door (1.5" thk; Door with lock & paint included	
10.	Formwork for slab	
11.	Rebar- 10mm-slab(2 Layer-Both direction)	
12.	4"x2" I-Beam – 10'-0" (For overhead water tank)	
13.	Tiling work(Bath & WC room)	
14.	Electrical & Sanitary ware	

**[Total in word: Kyats \_\_\_\_\_]**  
**(Two years warranty)**

I have visited/not visited the site before submission of tender documents. I have read terms & conditions of the bids and these are acceptable to me.

Signature of contractor with seal: \_\_\_\_\_

Date: \_\_\_\_\_

2'-0" x 2'-0" x 2'-0" Overhead Water Tank  
59.84 Gallon or 226.53 Liter

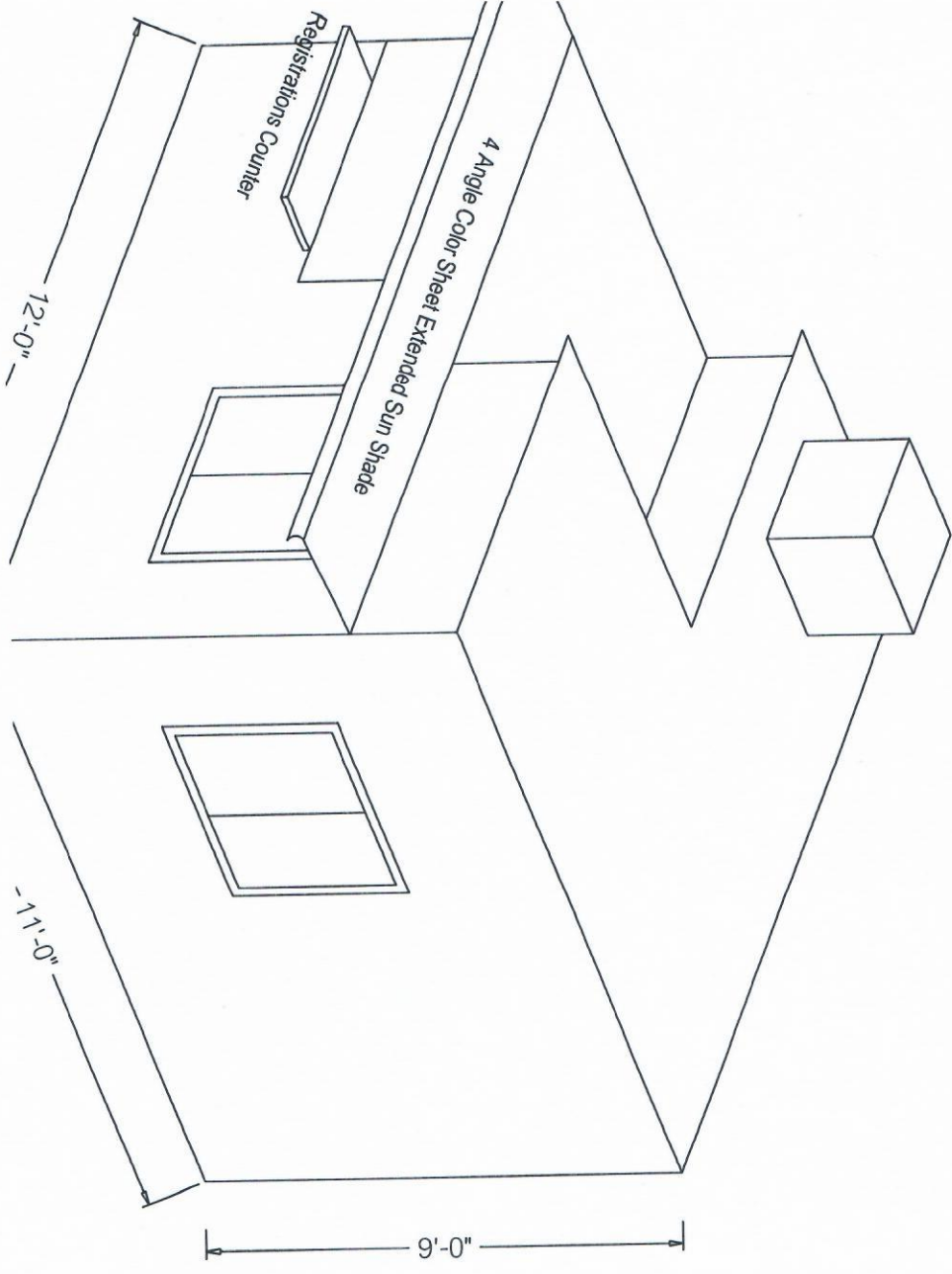

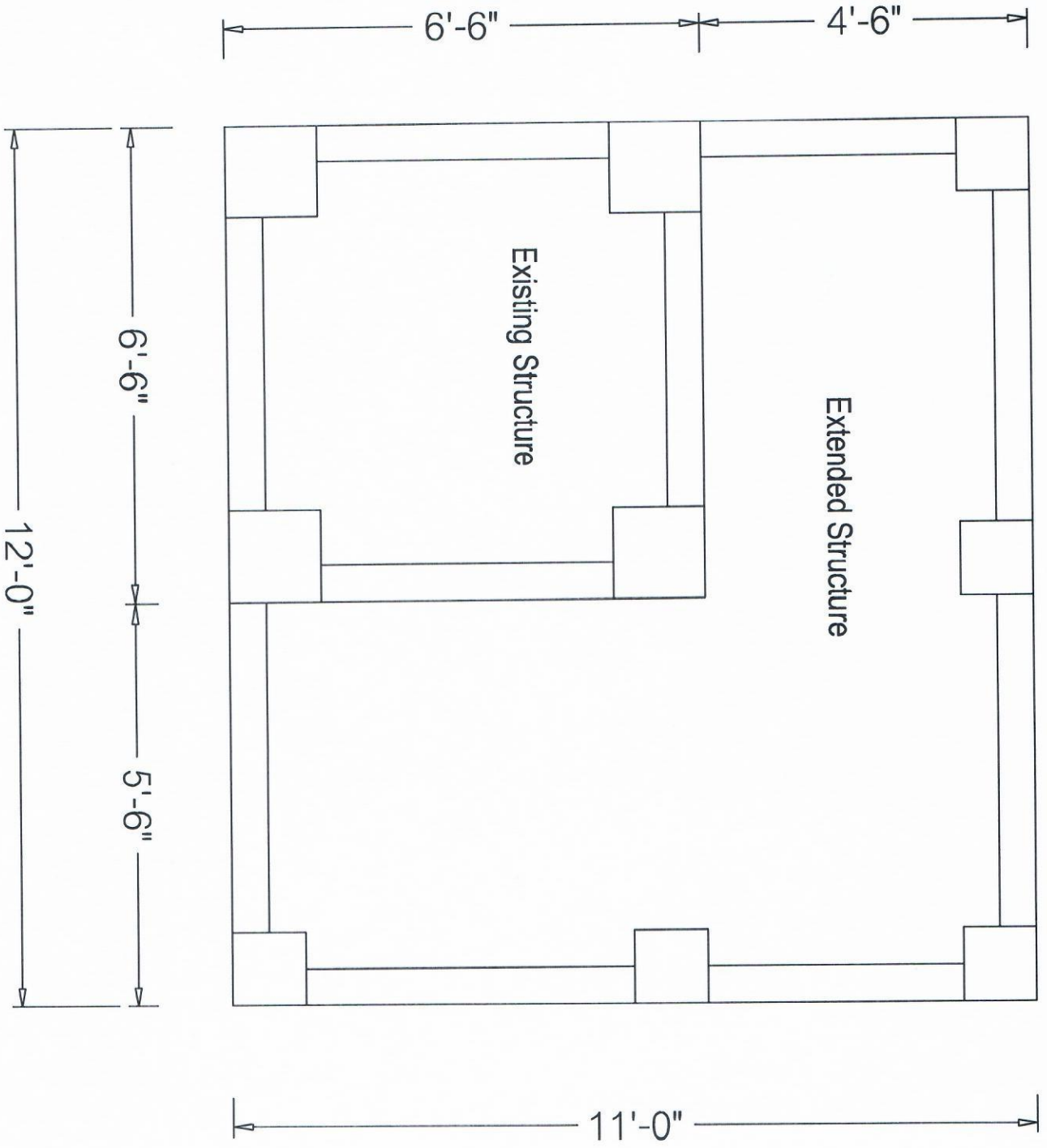

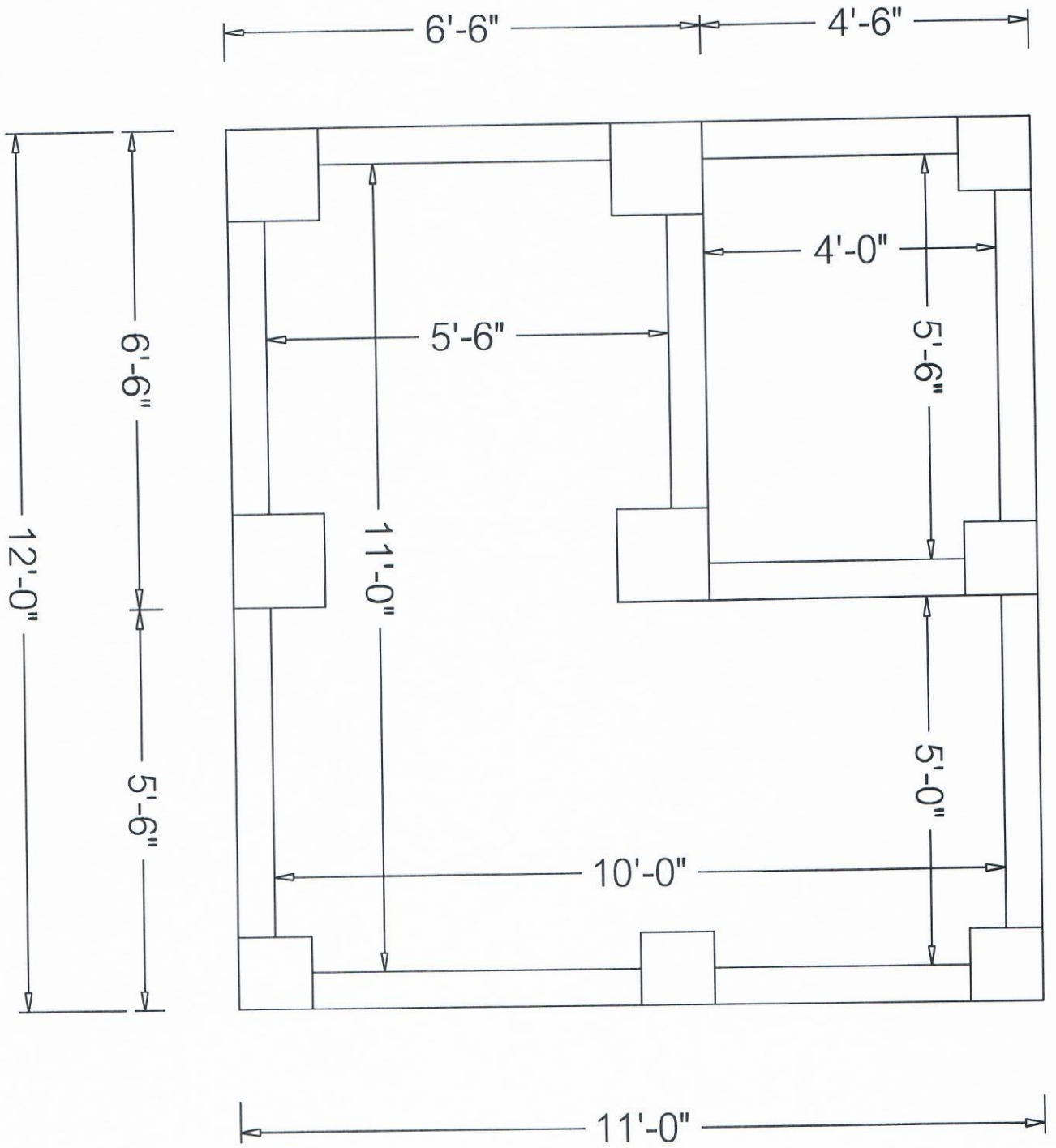



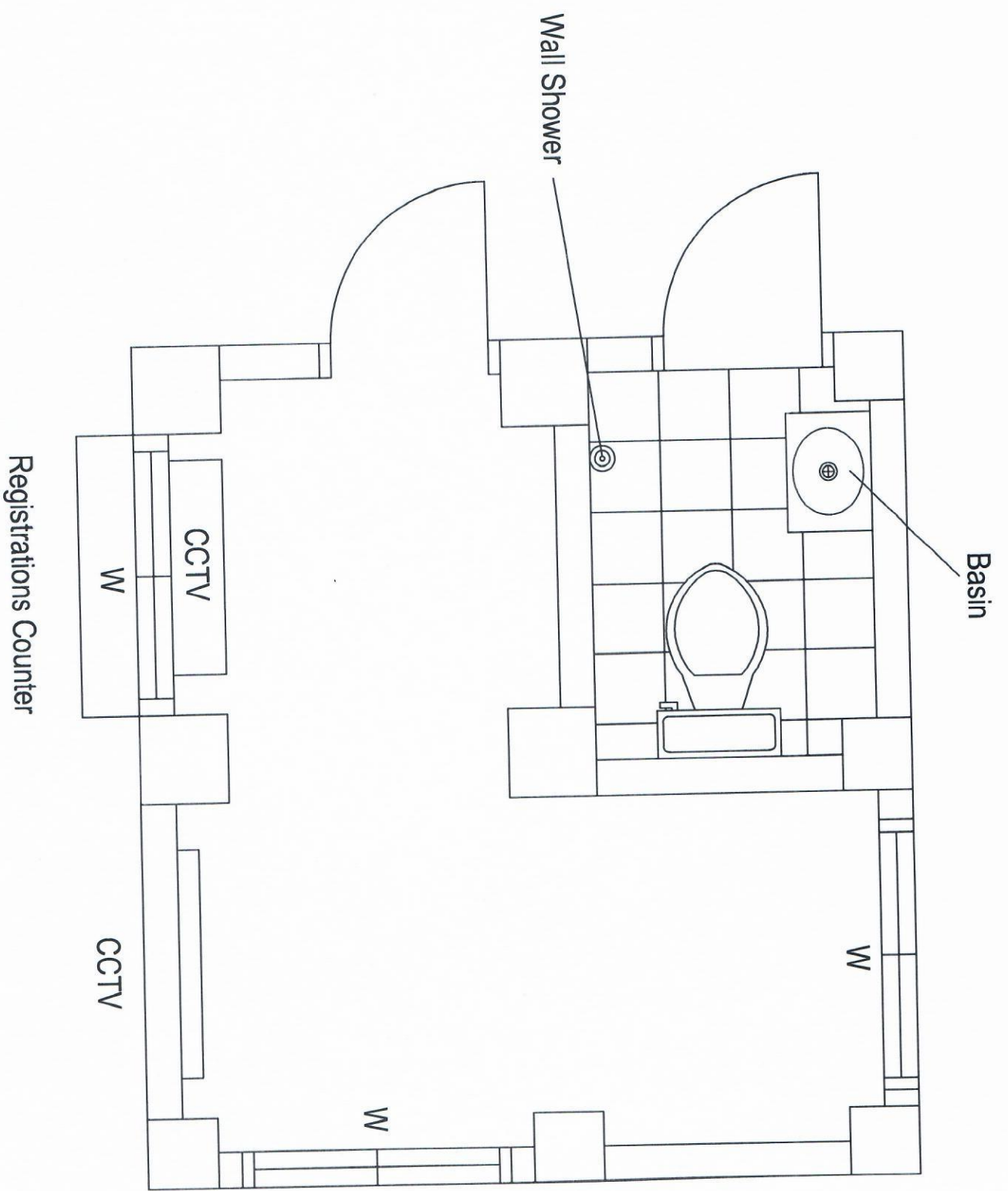

Basin

Wall Shower

Registrations Counter

CCTV

W

CCTV

W

W

2'-0" x 2'-0" x 2'-0" Overhead Water Tank  
59.84 Gallon or 226.53 Liter

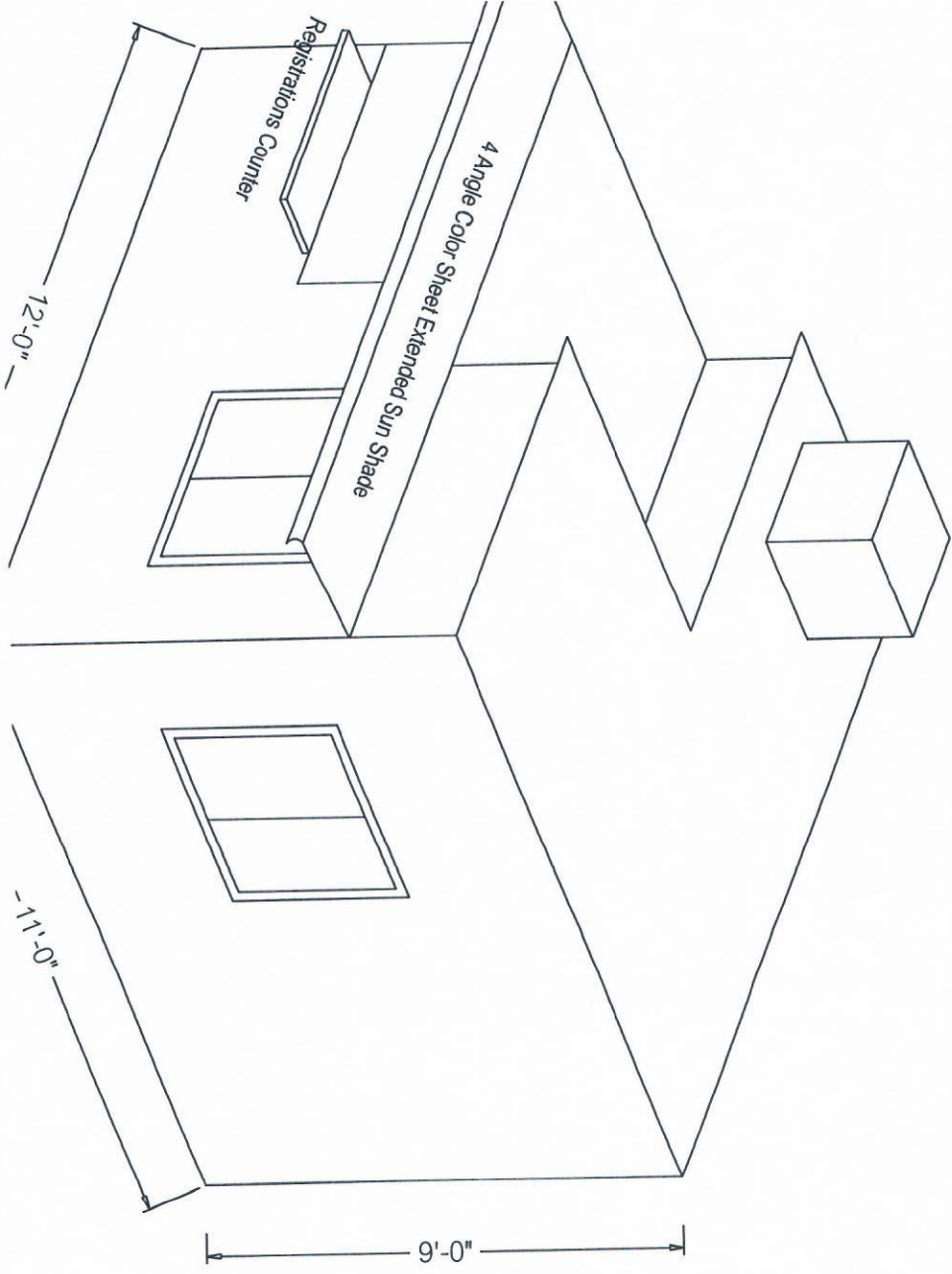

250'-0" from Main Water Supply

2'-0" x 2'-0" x 2'-0" Overhead Water Tank  
59.84 Gallon or 226.53 Liter

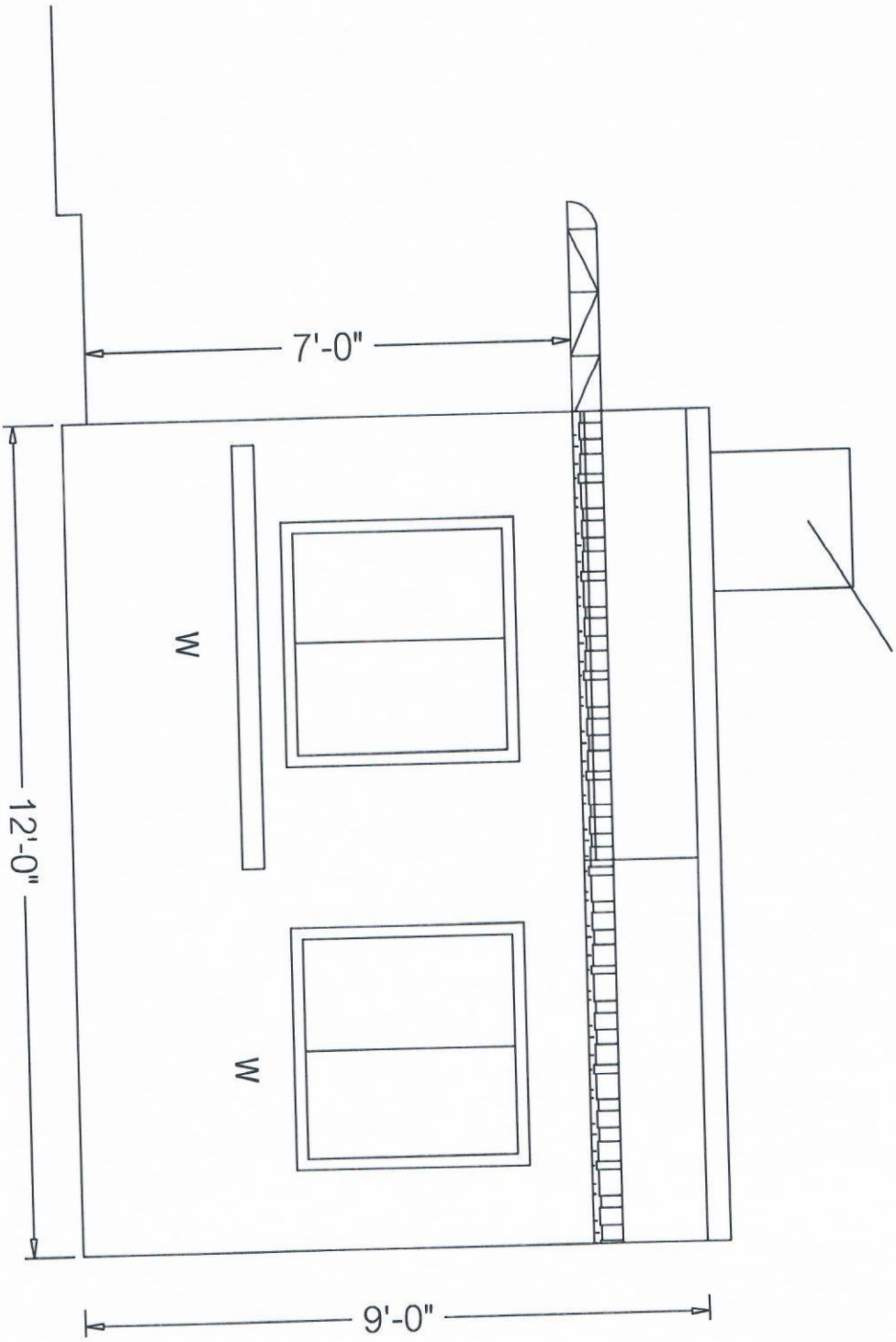

Front View

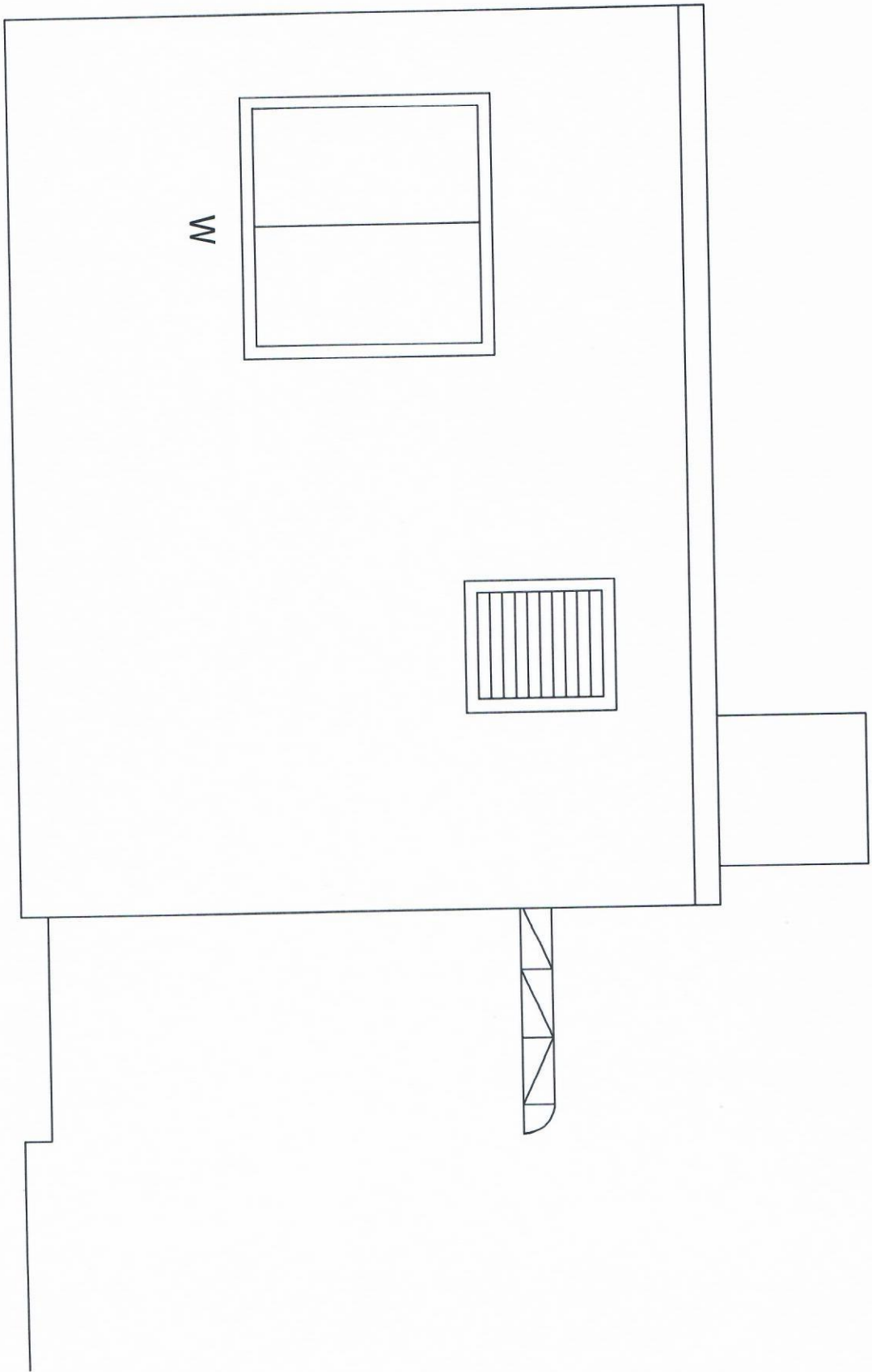

Back View

Left Side Elevation

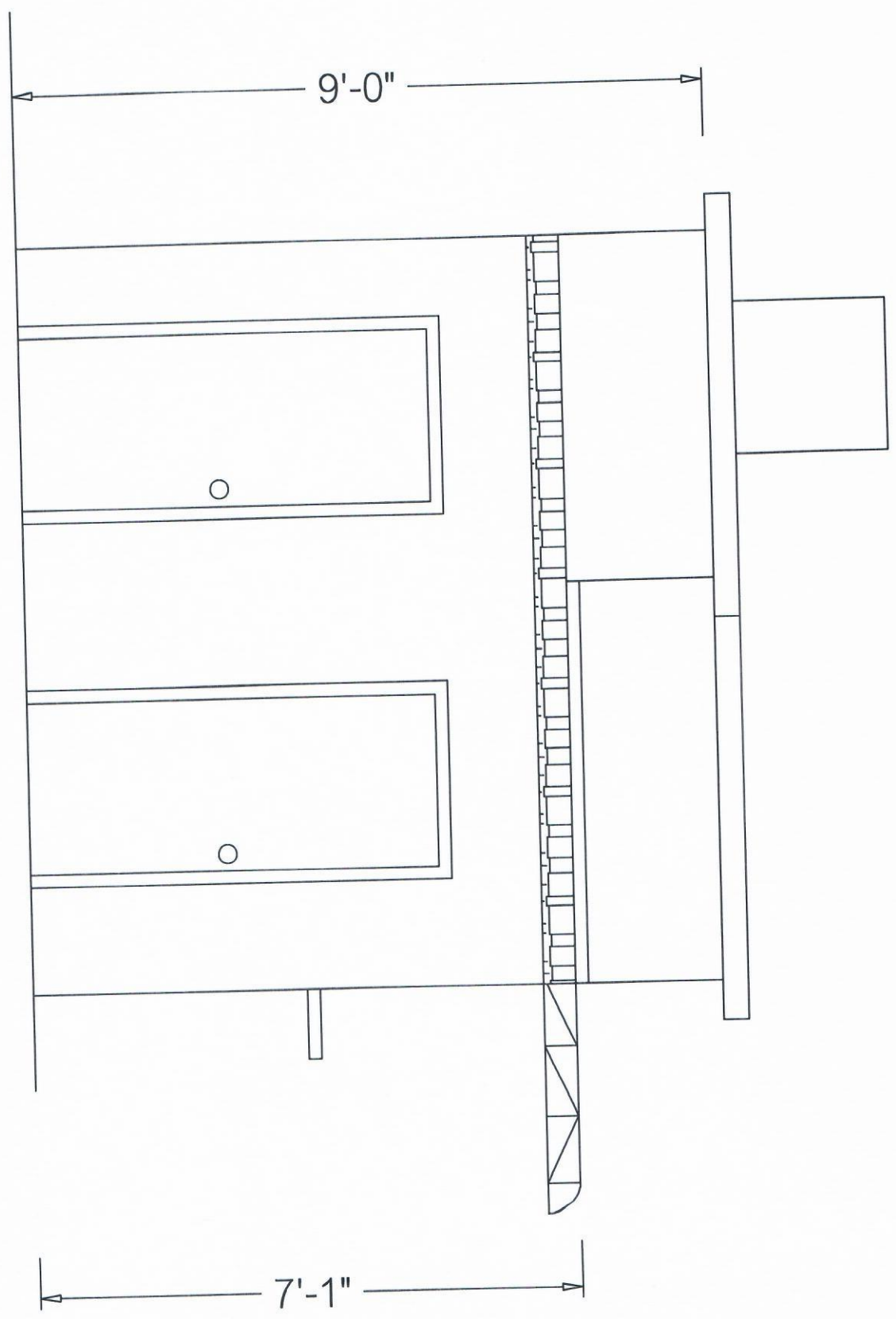

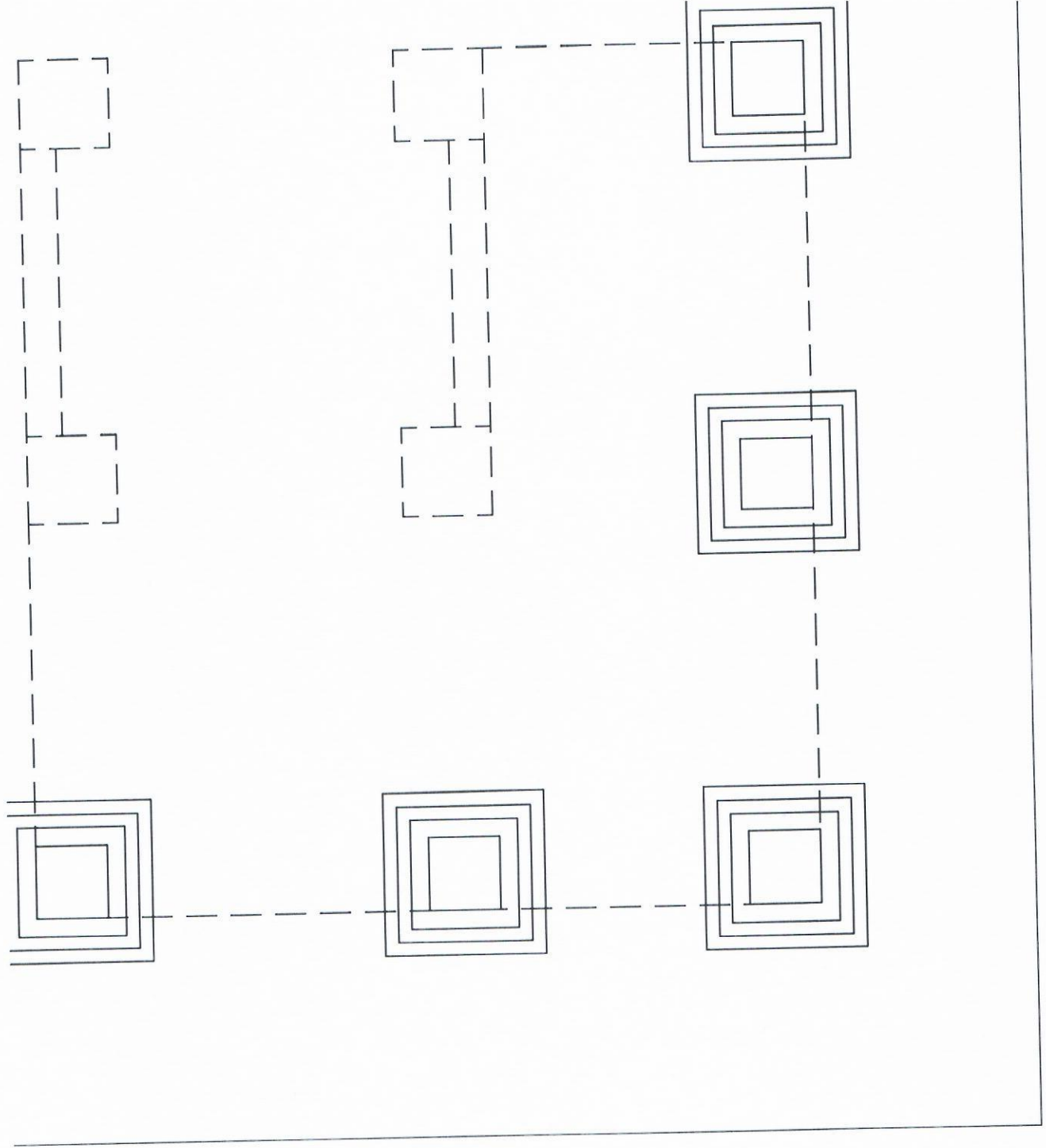

Retaining Wall Plan

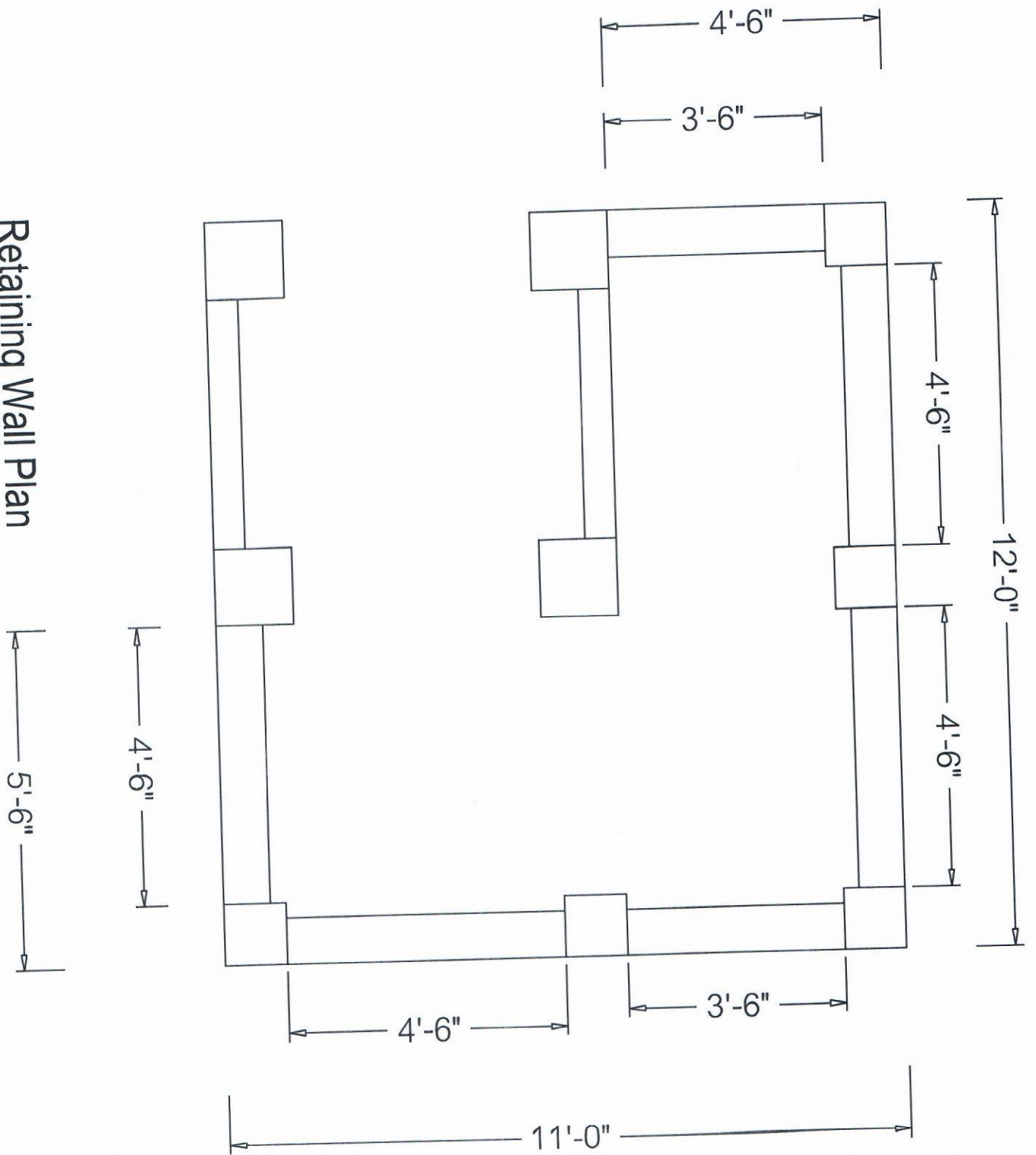

Slab Plan

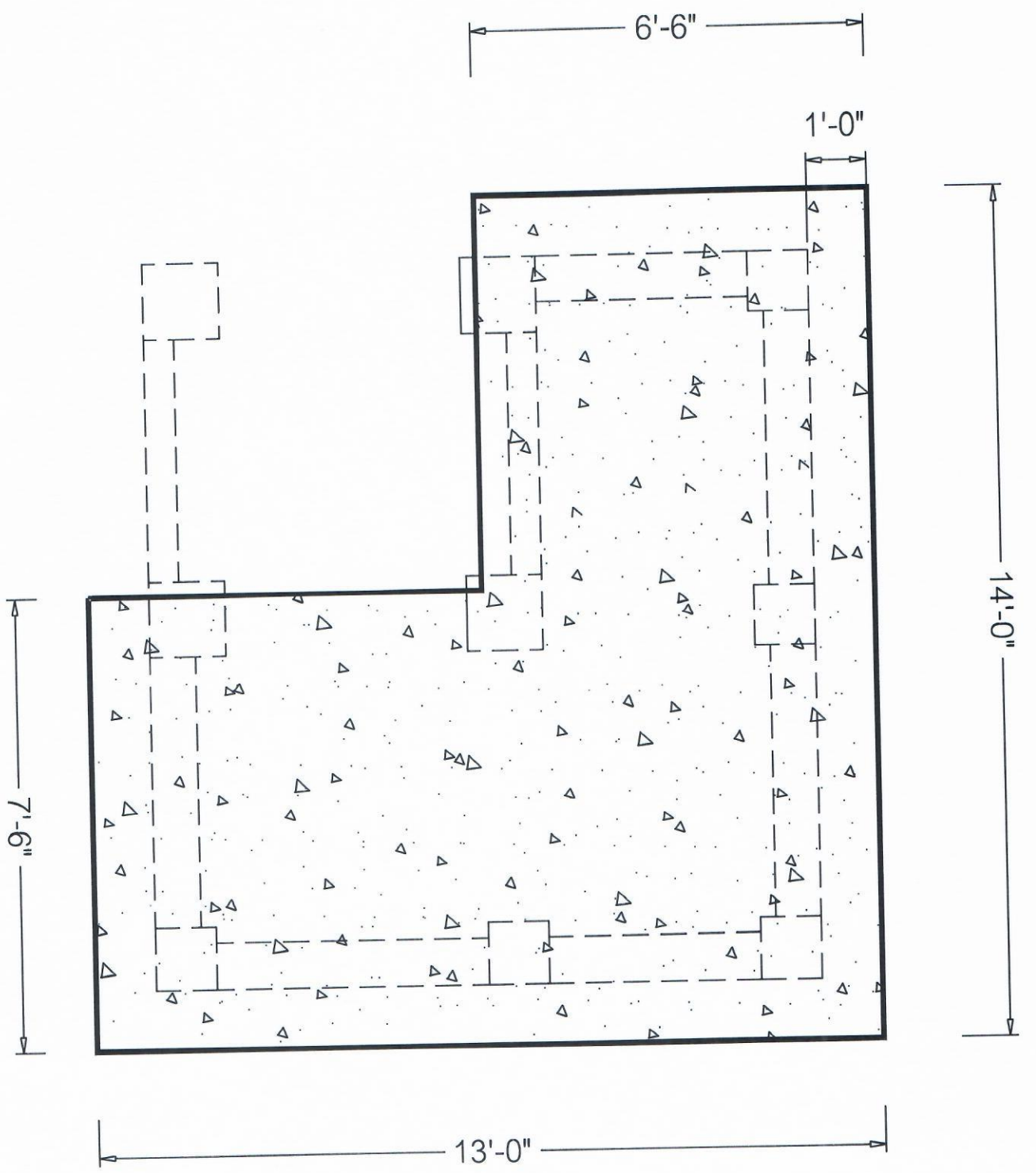



Slab Reinforcing Bar Plan

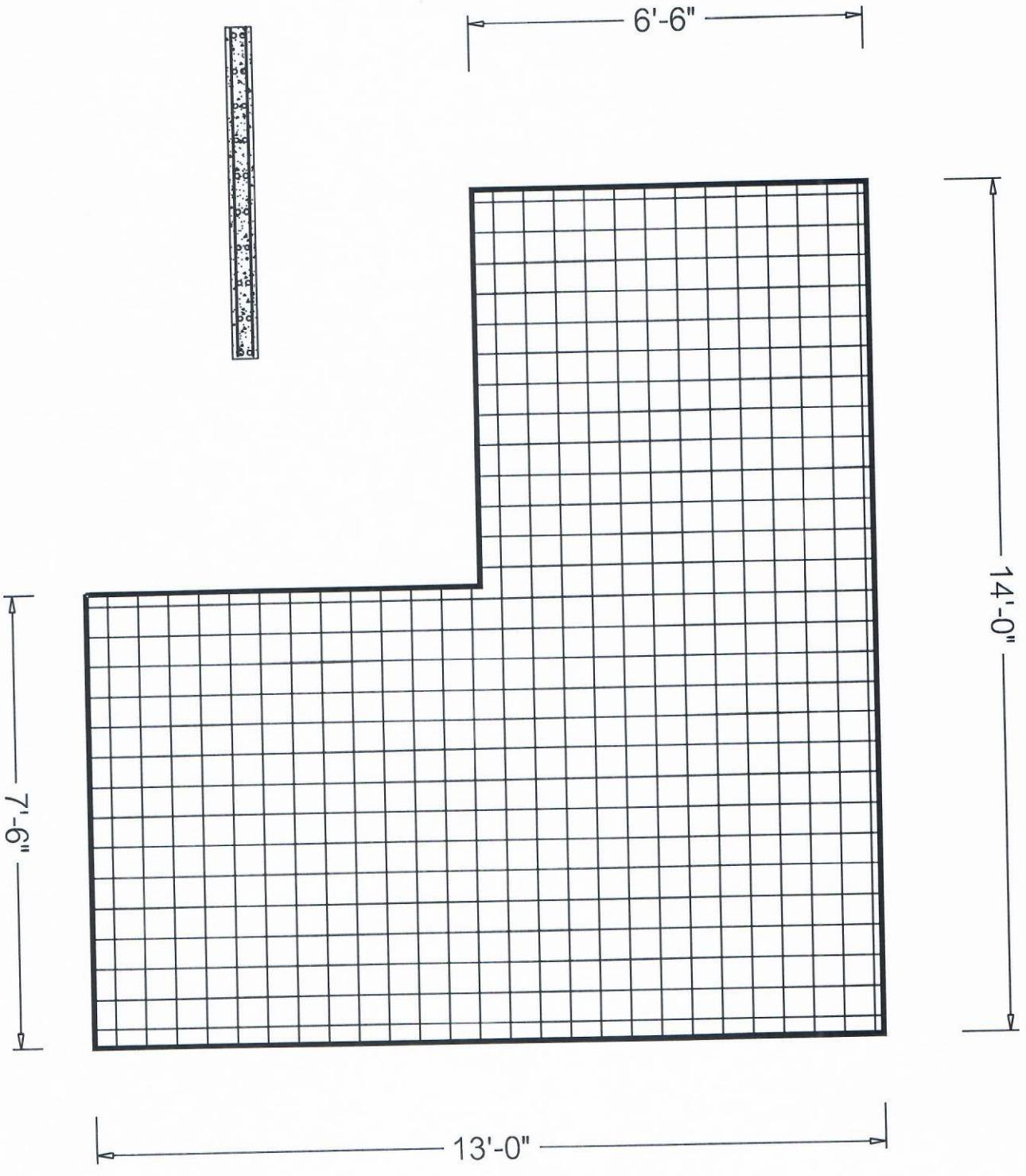

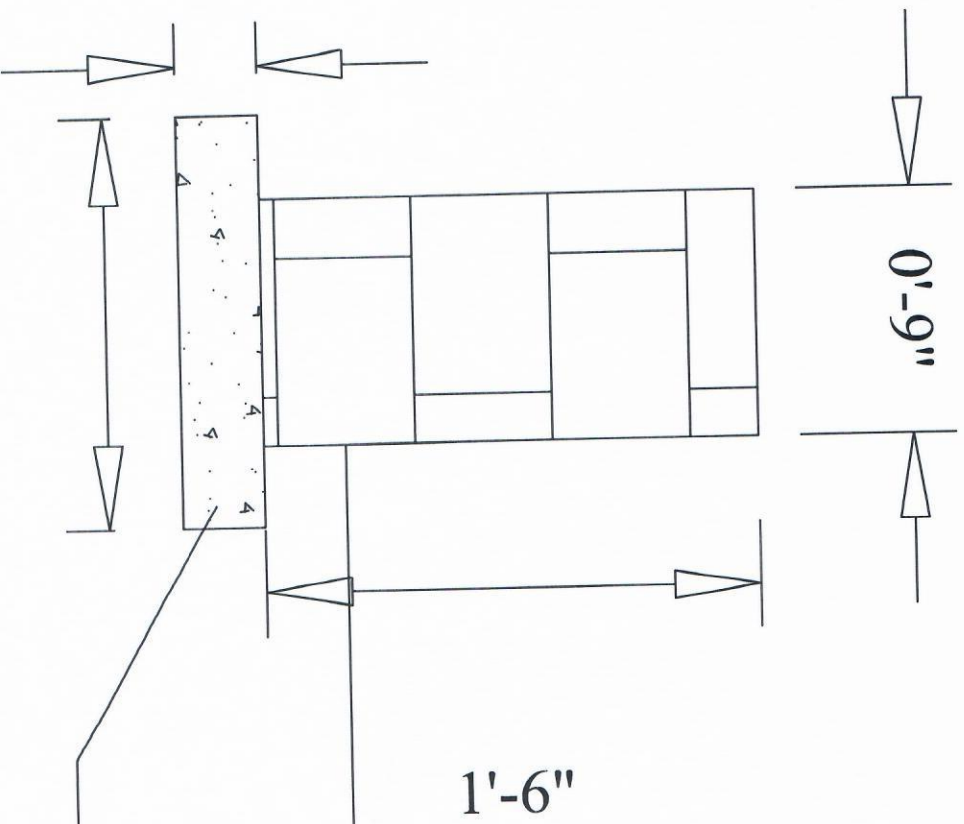

Natural Ground Level

3" thk; 1:3:6 Lean Concrete

1'-3"

9" thk; & 1'-6" Depth Retaining Wall

2" thk; 1:2:4 Slab Topping

4" thk; 1:2:4 Reinforced Concrete Slab

1'-0" x 1'-0" x 8'-8" Brick Column

9" thk; & 1'-6" Depth Retaining Wall

1'-4.5" thk; & 1'-3" Depth Brick Wall Footing

1'-9" thk; & 1'-6" Depth Brick Wall Footing

3" thk; 1:3:6 Lean Concrete

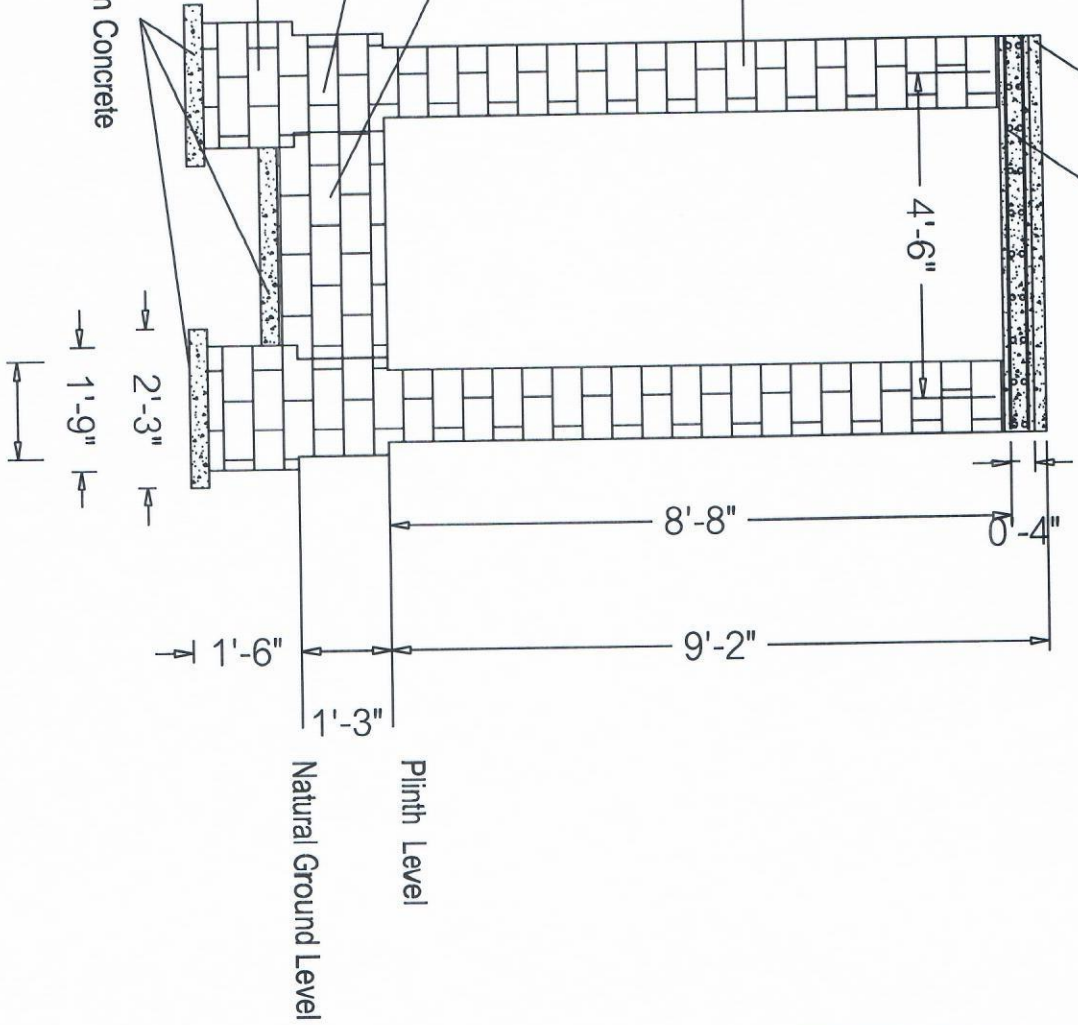

4'-6"

8'-8"

9'-2"

Plinth Level

Natural Ground Level

2'-3"

1'-9"

1'-4 1/2"

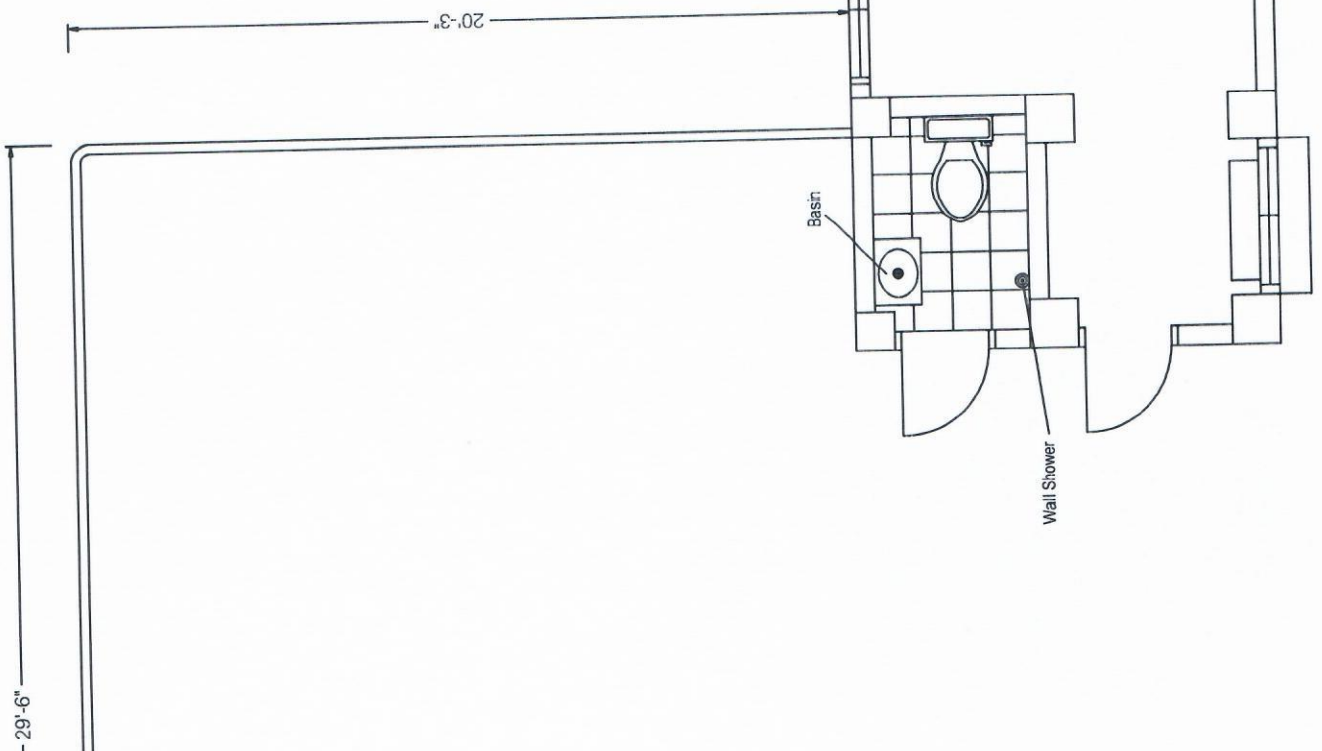
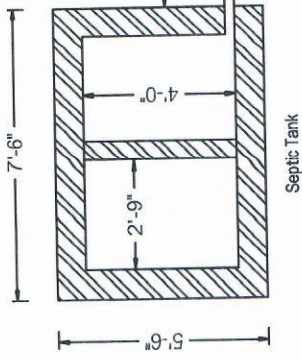

## SECURITY GUARD HOUSE & SEPTIC TANK

No	Description	Brand	Unit;	Qty;
1	1C x 2.5mm <sup>2</sup> Pvc Wire	Magnun	Coil	2
2	1C x 1.5mm <sup>2</sup> Pvc Wire	Magnun	Coil	2
3	1C x 4mm <sup>2</sup> Pvc Wire	Magnun	M	30
4	1C x 10mm <sup>2</sup> Pvc Wire	Magnun	M	20
5	12W LED Panel Light	FSL	Nos	4
6	1" Pvc Trunking	Pvc Link	Nos	15
7	2 x 3 Pvc Trunking	Pvc Link	Nos	2
8	Ø4" Pvc Pipe (13.5) For Soil		Nos	3
9	Ø2" Pvc Pipe (8.5)		Nos	2
10	Ø1-1/4 Pvc Pipe (8.5)		Nos	1
11	Ø1" Pvc Pipe (13.5)		Nos	14
12	Ø3/4 Pvc Pipe (13.5)		Nos	1
13	2 Way Valve		Nos	1
14	1 Way Valve		Nos	1
15	Wall Tap		Nos	1
16	Basin Tap		Nos	1
17	Gate Valve (1/2")		Nos	2
18	Flexible Hose (18" - Steel)		Nos	1
19	Wall Shower		Nos	1
20	Basin		Set	1
21	Ewc - American Standard		Set	1
22	Base Cup		Nos	3
23	1 Gang 1way Switch	Megalec	Nos	1
24	2Gang 1 Way Switch	Megalec	Nos	1
25	2' x 2' x 2' (Overhead Water Tank)	Fiber Tank	Nos	1
26	Cat 6 Cable (For CCTV)		M	25

27	Labour Cost For Remove All Existing Panel		Lot	1
	Other Accessories (Wall Plug And Wire Tape,,, ETC?????)		Lot	1
28	Water Motor - 1 Hp			
29	Pressure Pump			
30	Hand Spray			
31	Exhaust Fan			